

Follow the steps to fold the table flat for easy storage after it's assembled

Folding Step 1 :

1. Press the buttons as shown to slide/adjust the leg frame.  
Attention: This step will require two people to operate adjustment at the same time.

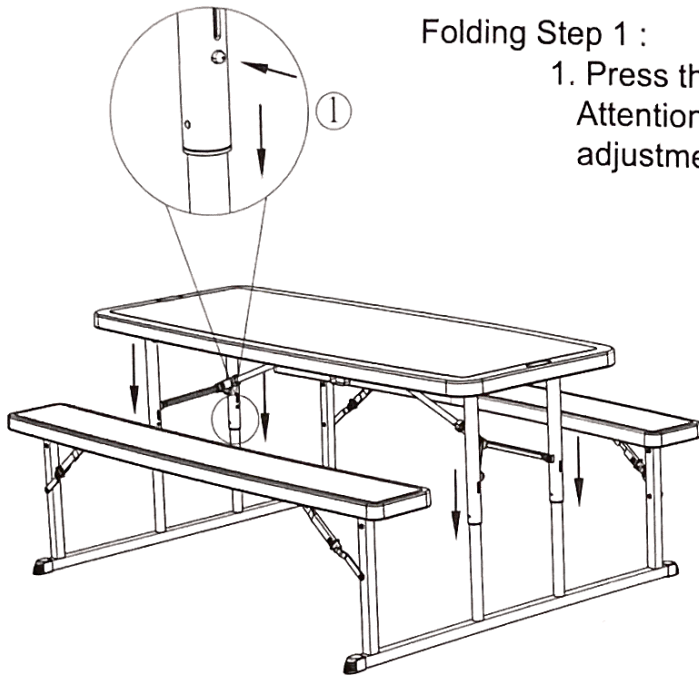

\*\*Legs need to be lowered before folding.

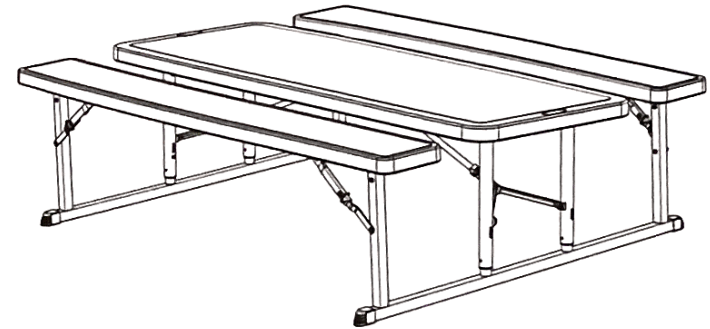

Caution: Leg frame might fall extremely fast and could be dangerous while folding, please operate step 2 slowly with care.

Folding Step 2 :

1. Turn table up-side down.
2. Release the safety lock as shown and then fold in leg frame.
3. Fasten the leg frame to the table top with velcro straps.

